



Title : LuxCis maintenance kit

Series  
OUT

Issue  
17 Nov 04

Page  
1/2

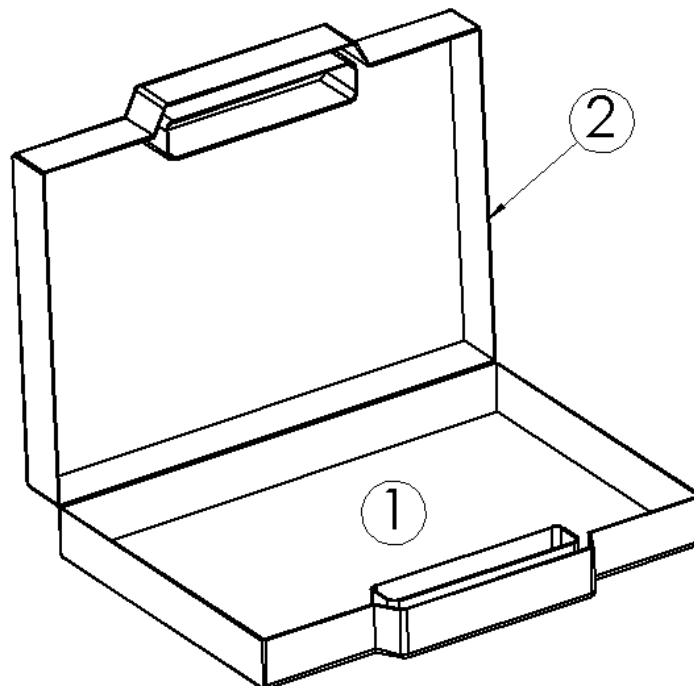
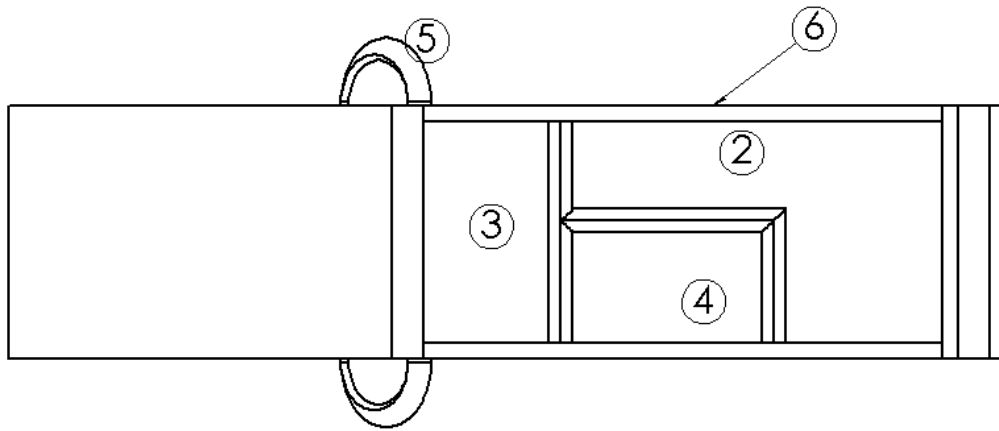

CREATION					<b>RADIALL</b> <sup>®</sup> 101, rue P. Hoffmann 93116 ROSNY/BOIS FRANCE Tel : (33) 0149353535 Fax : (33) 0148546363
N°:					
PEN/EP EPF 04-01					
Name: SP					
Date: 17 nov 04					
Appr.: AM	Issue	Revisions	Name	Appr.	



Title : LuxCis maintenance kit

Series  
OUTIssue  
17 Nov 04Page  
2/2

## Content of the kit

Reference	Rep	Qté	Description
		5 1	Badge for bags label
		2 1	Box
		1 1	Roll adhesive tape
282 546		1 1	Insertion & extraction tool
503 08 590		2 1	Maintenance & cleaning procedure
F718 176 201		1 1	Bag of 10 protective cap for LuxCis contact
F780 527 000		1 1	Bag of 6 pockets cleaning papers
F780 652 000		4 1	Microscope X100
F780 809 000		3 1	Alcohol dispenser
F780 855 000		1 1	Hexagonal key 5/64 inch (2mm) / flat
F780 856 000		1 1	Bag of 10 cleaning pipes 1.25mm
F780 857 000		1 1	Bag of 10 cleaning sticks 1.25mm

The referenced products can be ordered separately.

## General

Function : used to clean LuxCis plug (F725 serie)  
Weight : 1.6 Kg  
Operating temperature : 0 / +40°C  
Storage temperature : -10 / +55°C

Consumable which are not in the tool kit : alcohol and canned air